

**ISOTRA®**

TECHNICAL MANUAL

# JAPANESE PANEL BLINDS



---

## Table of Contents – Japanese Panel Blinds

Basic Product Specification	4
Measuring Instructions	9
Configurations	11
Safety features according to the standards EN 13120+A1; EN 16 433; EN 16 434	15

Products in this assortment group are always measured from the interior.

Due to continuous development of our products, we reserve the right to slight differences in design from the illustrations.

---

### **ISOTRA***Quality*

A brand symbolizing years of tradition, innumerable investments into research and development, use of high-quality materials, technological advancement, reliable work of hundreds of employees and many more parameters, which together form one whole - the final product of the company ISOTRA.

## Japanese Panel Blinds



- ▲ original design for complex shading regardless of number of windows or wings
- ▲ alternative to blinds and roller blinds
- ▲ rails made of extruded aluminum in white or silver color
- ▲ wide range of fabrics of various decors and materials

**ISOTRA** *Quality*

# Japanese Panel Blinds

## Basic Product Specification

Cord control / Wand control

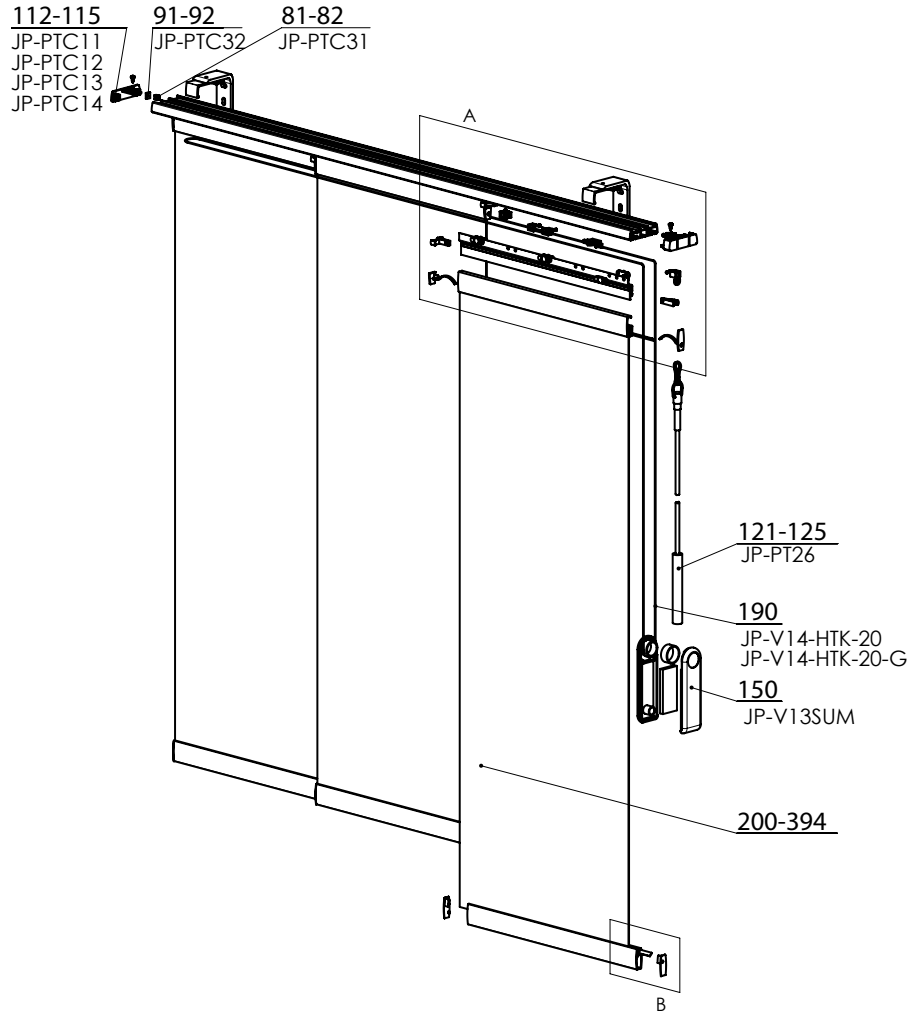

2-00585-XXXX-B

Detail A

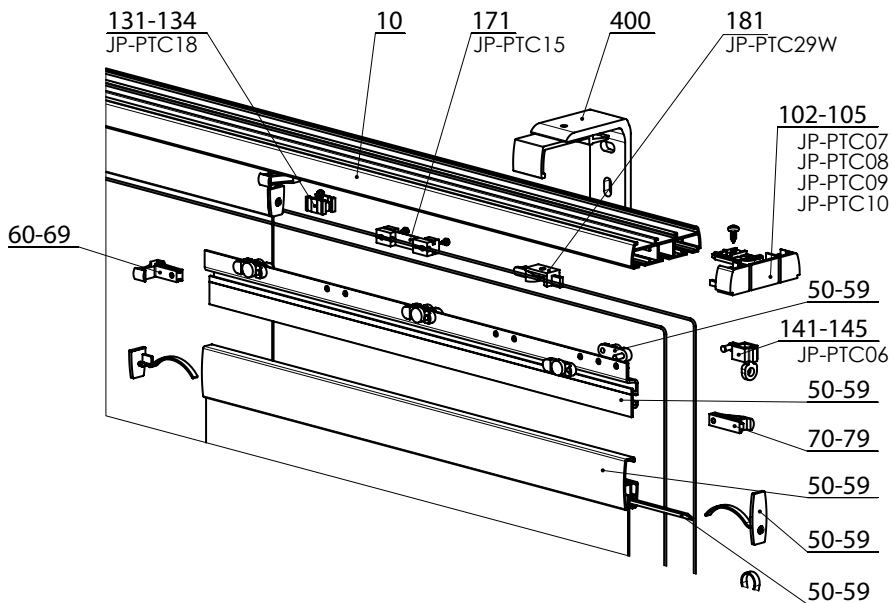

Detail B

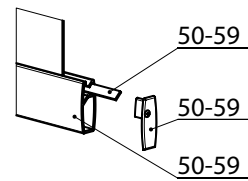

**Japanese panel blinds 2-00585-9999**

Position	Name od components	Abbreviation	Number of tech. dvawing
10	Profiles		Profiles and profile holders
50 + 60 + 70	One panel set		Panel set
81-82	Counter magnet	JP-PTC31	6-009315-0000
91-92	PTF Magnet	JP-PTC32	6-009316-0000
102	Ending support - cord 2-channel	JP-PTC07	6-009296-xxxx
103	Ending support - cord 3-channel	JP-PTC08	6-009297-xxxx
104	Ending support - cord 4-channel	JP-PTC09	6-009298-xxxx
105	Ending support - cord 5-channel	JP-PTC10	6-009299-xxxx
112	Ending support - simple 2-channel	JP-PTC11	6-009300-xxxx
113	Ending support - simple 3-channel	JP-PTC12	6-009301-xxxx
114	Ending support - simple 4-channel	JP-PTC13	6-009302-xxxx
115	Ending support - simple 5-channel	JP-PTC14	6-009303-xxxx
121-125	Control rod - 114cm	JP-PT26	6-009288-xxxx
131-134	Adjustable stop	JP-PTC18	6-009312-xxxx
141-145	Control eye	JP-PTC06	6-009295-xxxx
150	Cord weight - roller	JP-V13SUM	6-009282-xxxx
171	Cord connector	JP-PTC15	6-009286-xxxx
181	Adjustable cord slider	JP-PTC29-W	6-009314-9016
190	Cord - white	JP-V14-HTK-20	6-009284-0000
190	Cord - grey	JP-V14-HTK-20-G	6-009285-0000
200 - 394	Fabric		See Sample
400	Profile holder		Profiles and profile holders



**Manual Control**

For pulling the fabric panels to the side, to the center or from the center (based on control method):

Cord – cord length = 2/3 of the Japanese panel blind height. White and silver color.

Wand – wand length: 1170 mm. White and silver color.

**Technical Details**

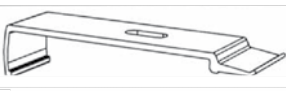
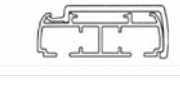
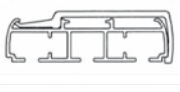
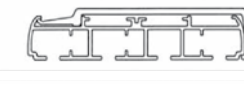
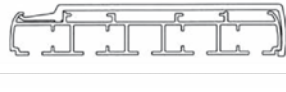
Upper beam type	2 channels	3 channels	4 channels	5 channels
Ceiling bracket				
Profiles				

Atypical Designs: yes

Material: Al

Installation in window aperture (ceiling) before window aperture (wall)

**Standard Dimensions**

Minimum Width (mm)	Maximum Width (mm)	Minimum Height (mm)	Maximum Height (mm)
1000	5800	1000	3200

Note: In the case of the height exceeding 2700 mm, the fabric choice must be consulted with the manufacturer.

The maximum size of the individual panels is given by the dimensional limit of the individual fabrics.

Determination of the individual panel width depends on the carrying bracket type, resp. on the number of required panels and total width of the accessory.

Panel set

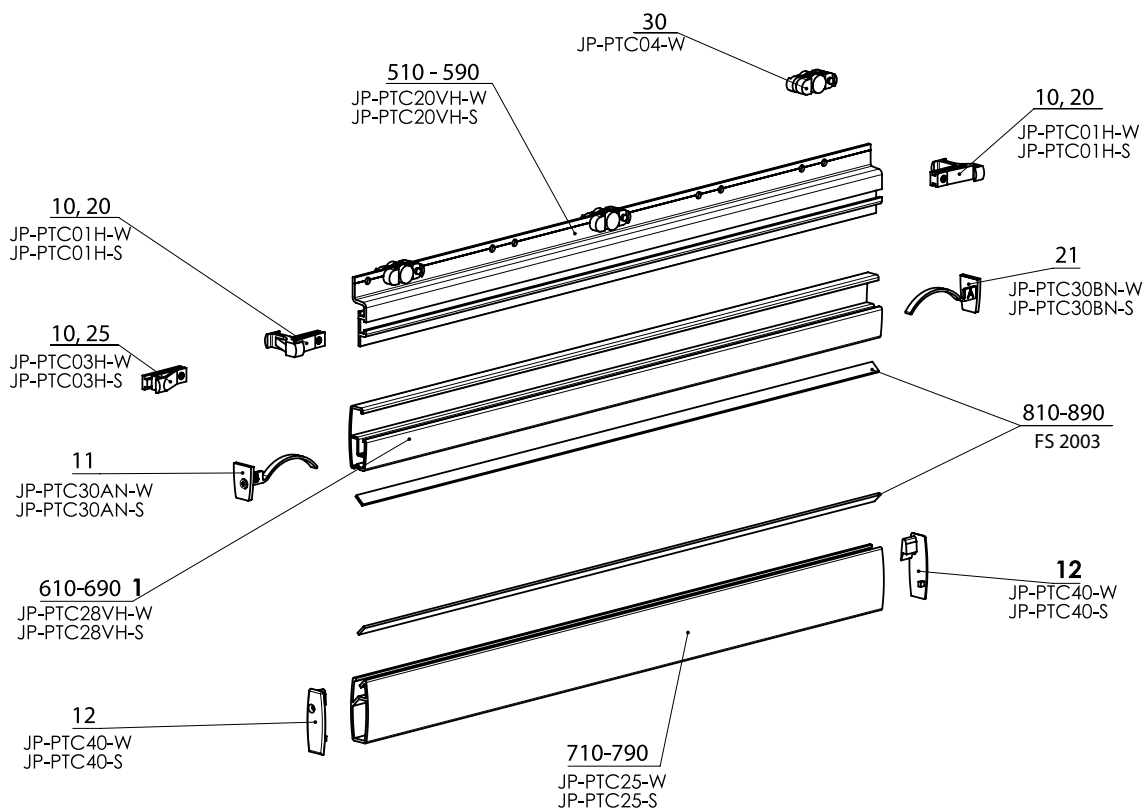

SET 1 PANELU 2-00743-XXX

Panel set 2-00743-0000

Position	Name od components	Abbreviation	Number of tech. drawing
11	Plug - hanging profile	JP-PTC30AN	6-009261
12	Plug - weight	JP-PTC40	6-012343
21	Plug - hanging profile - right	JP-PTC30BN	6-009262
30	Slider - white	JP-PTC04-W	6-009293
510 - 590	Running profile PVC	JP-PTC20VH	6-009268
610 - 690	Hanging profile panel	JP-PTC28VH	6-009267
710 - 790	Weight panel - white	JP-PTC25	6-009271
810 - 890	Tape	FS 2003	6-017815-0000
10 - 20	Pitch stop T	JP-PTC01H	6-009269-9016
10 - 25	Pitch stop L	JP-PTC03H	6-009270-9016

W - white  
S - silver

## Profiles and profile holders

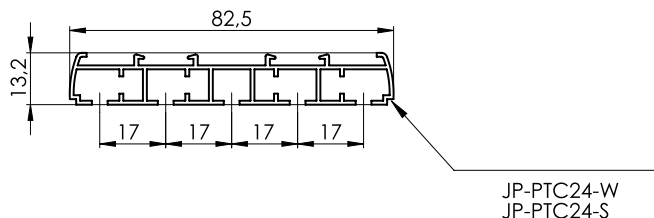
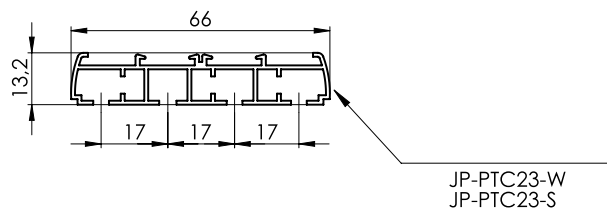
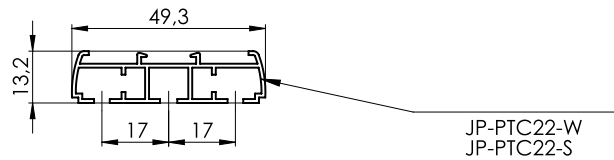
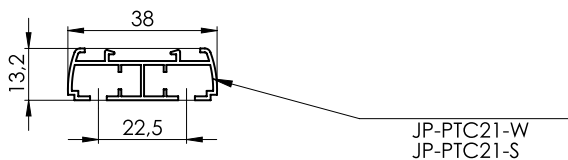

## Ceiling attachments

JP-PTC17C2, 6-009331-XXXX

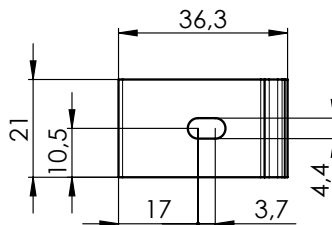
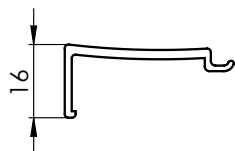
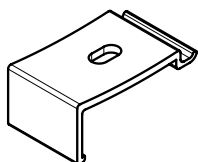

JP-PTC17C3, 6-009332-XXXX

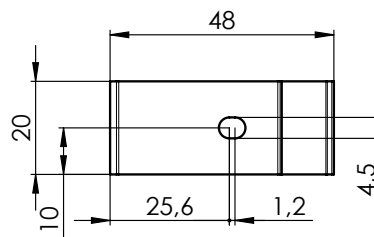
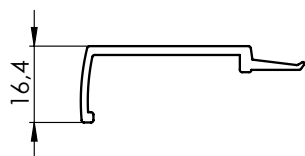
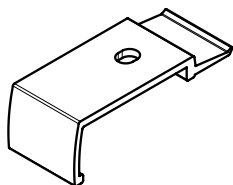

JP-PTC17C4, 6-009333-XXXX

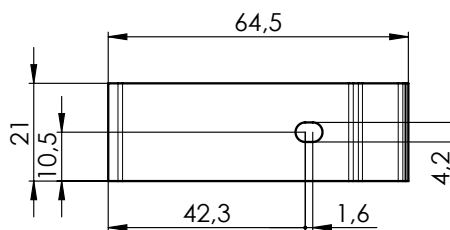
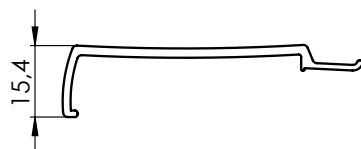
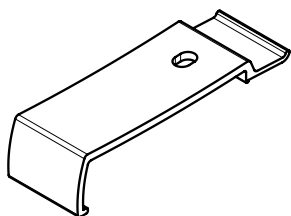

JP-PTC17C5, 6-009334-XXXX

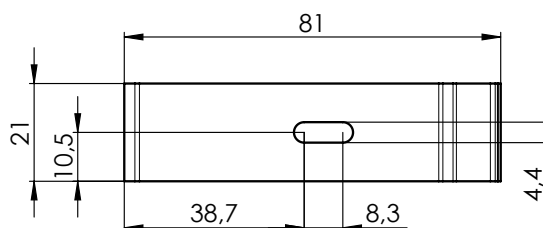
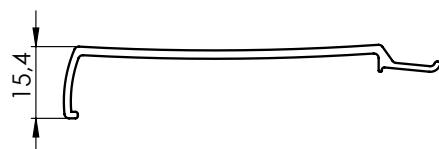
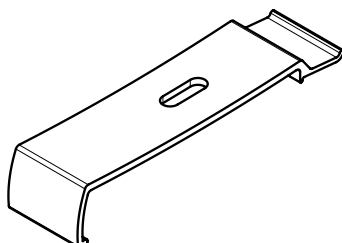

## Wall brackets

JP-PTC17WB-23, 6-009341-XXXX

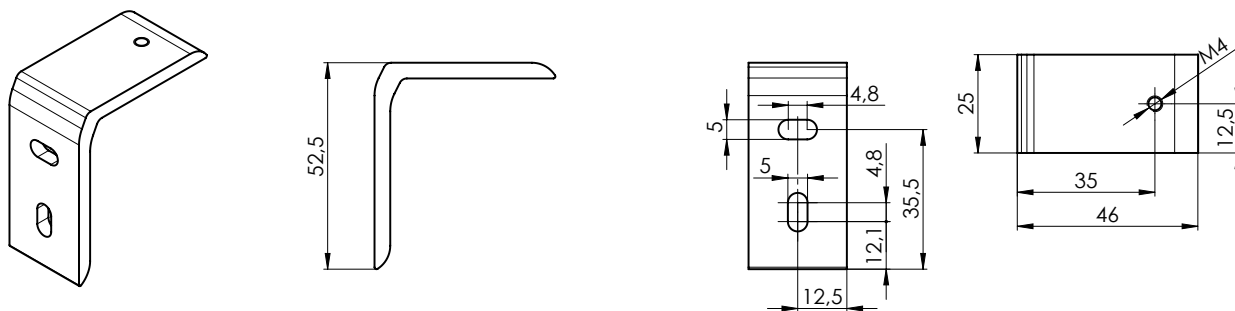

JP-PTC17WB-45, 6-009342

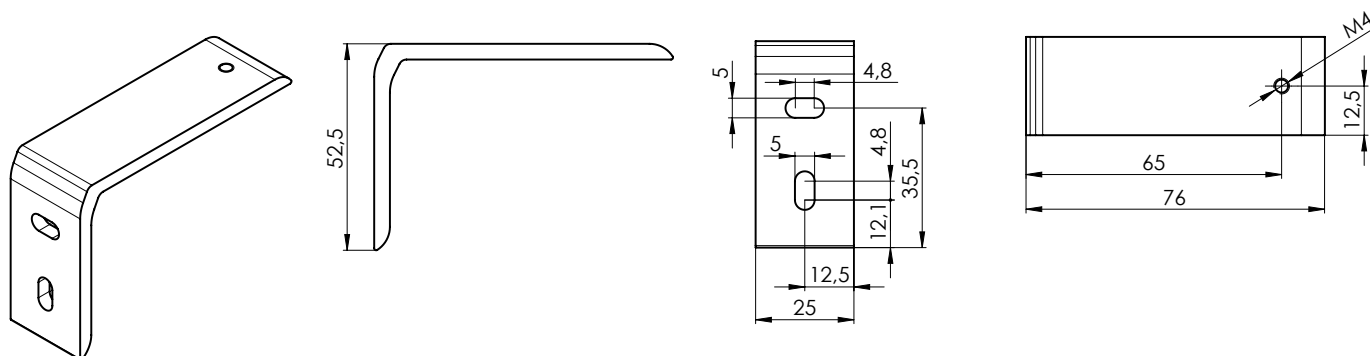

### Profiles and profile holders - position 10, 400

Position	Name of components	Abbreviation	Number of tech. drawing
10	Support 2-channel	JP-PTC21	6-009263-xxxx
10	Support 3-channel	JP-PTC22	6-009264-xxxx
10	Support 4-channel	JP-PTC23	6-009265-xxxx
10	Support 5-channel	JP-PTC24	6-009266-xxxx
400	Bracket - wall - medium	JP-PTC17WB-45	6-009342-xxxx
400	Bracket - wall - small	JP-PTC17WB-23	6-009341-xxxx
400	Bracket - ceiling - 4-channel	JP-PTC17C2	6-009331-xxxx
400	Bracket - ceiling - 5-channel	JP-PTC17C3	6-009332-xxxx
400	Bracket - ceiling - 2-channel	JP-PTC17C4	6-009333-xxxx
400	Bracket - ceiling - 3-channel	JP-PTC17C5	6-009334-xxxx

## Japanese Panel Blinds

### Measuring Instructions

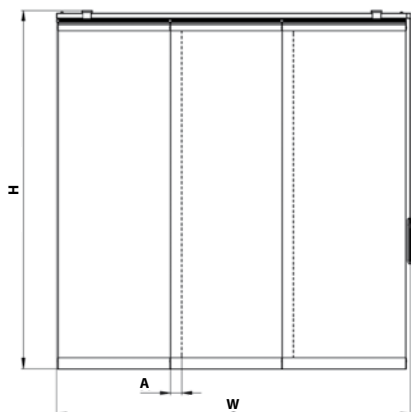

Japanese panel blinds are suitable for mounting to window hole (ceiling) or before the window hole (wall).

**W: total width of japanese panel**

We produce the width of japanese panel blinds in accuracy of mm from the width of 1000 mm to 5800 mm with tolerance of  $\pm 1$  mm.

**H: total height including the carrying profile**

We produce the height of japanese panel blinds in accuracy of mm from the width of 1000 mm to 3200 mm with tolerance of  $\pm 1$  mm.

Note: It's necessary to consult the choice of fabric with producer for height over 2700 mm.

**A: Overlapping of fabric (mm)**

Standard overlapping of fabrics is 50 mm.

**B: width of panel (mm)**

It's necessary to indicate the width of panel in case the head rail is longer then shaded surface - always necessary to consult with producer.

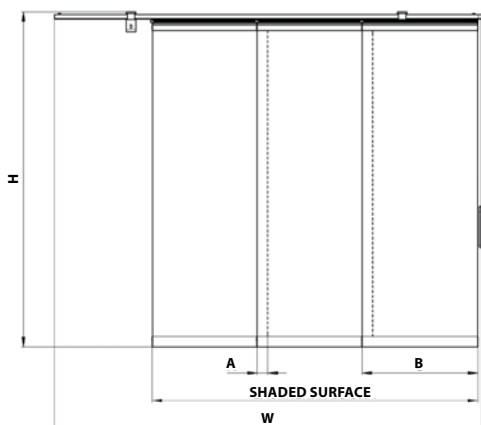

Maximal dimensions of each panel is limited by the dimension limit of particular fabrics.

Determination of the dimensions of each panel depends on the type of head rail, or more precisely on the number of panels and total width of system.

Dimensions over the standard limits is necessary to consult with producer.

### Number of attachments

Width (mm)	Number of Attachments
< 1000	2
1001 - 1800	3
1801 - 2600	4
2601 - 3400	5
3401 - 4200	6
4201 - 5800	7

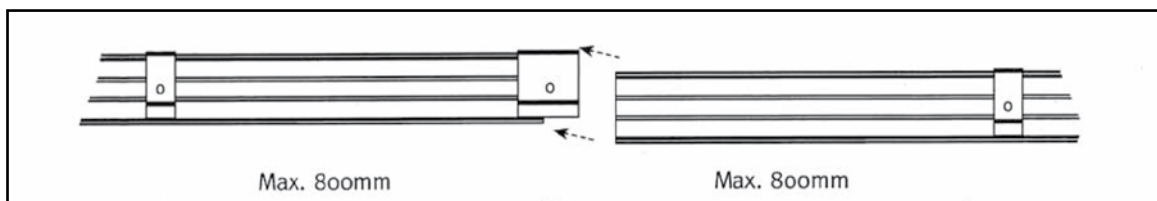

The carrying brackets to be connected using the PTC33C2, PTC33C3, PTC33C4, PTC33C5 connectors.

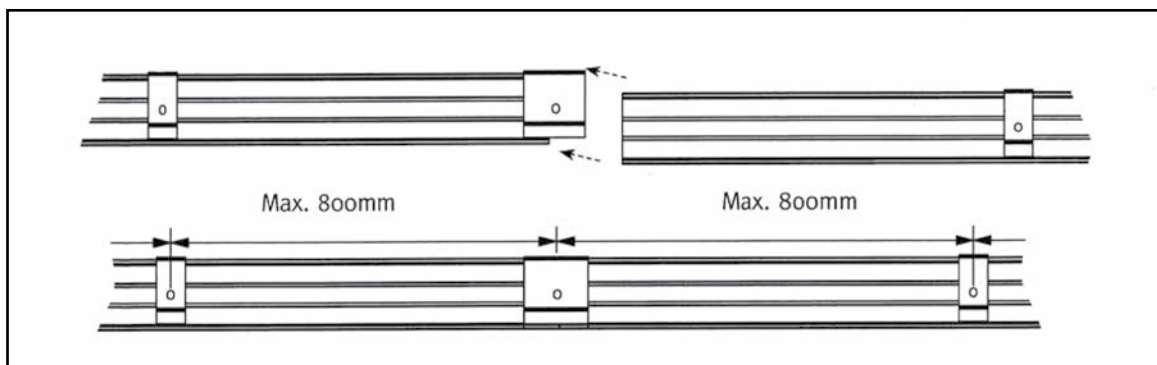

### Installation of Carrying Brackets

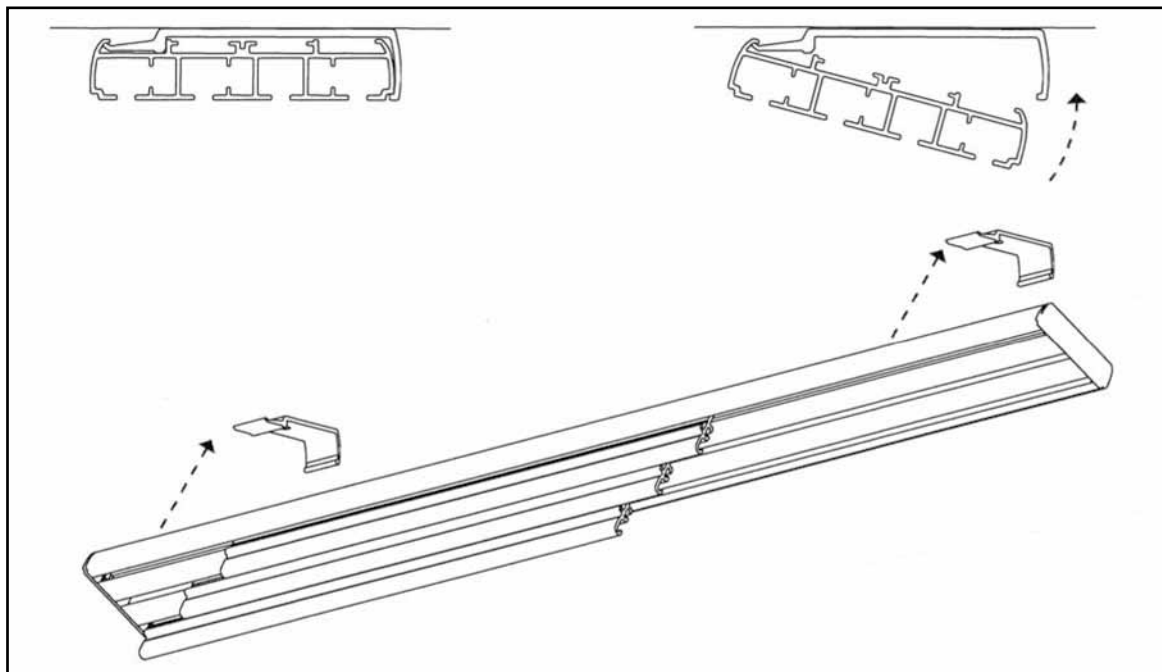

### Final Installation of Panels

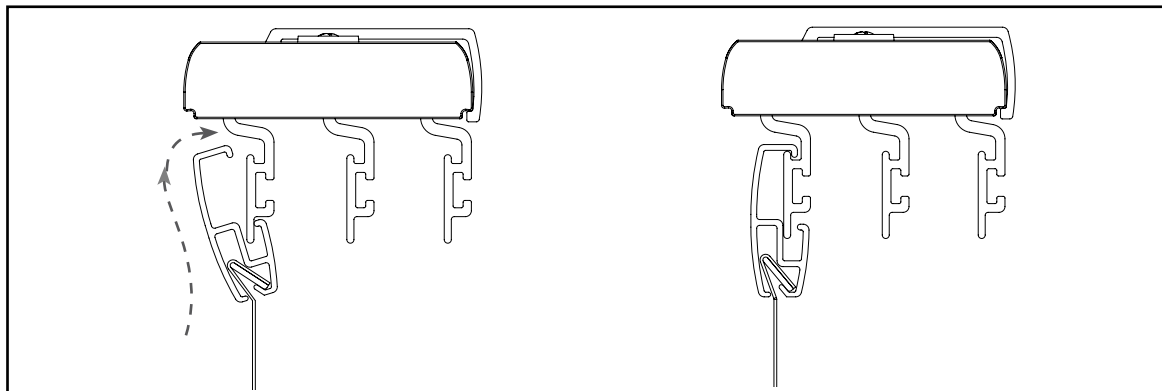

# Type of japanese panel: 2-rails profile

2/1 control bar - R (f.p. left bottom part)

2/2 control bar - L (f.p. right bottom part)

2/3 CURTAIN - 3 fabrics - control bar (f.p. bottom part)

2/4 control bar - R (f.p. left front part)

2/5 control cord - L (f.p. left bottom part)

2/6 control cord - R (f.p. right bottom part)

2/12 control bar - L (f.p. right front part)

2/13 CURTAIN - 3 fabrics - control bar (f.p. front part)

2/15 control cord - L (f.p. left front part)

2/16 control cord - R (f.p. right front part)

2/17 control cord - L (f.p. right bottom part)

2/18 control cord - R (f.p. left bottom part)

2/19 control cord - L (f.p. right front part)

2/20 control cord - R (f.p. left front part)

2/T control bar on each panel

f.p. - fixed panel  
In case of other possibility, necessary to consult with producer.

Legend	
	pulling direction
	position of fixed panel
	control bar / without control bar - pulling by fabric
	control cord
<b>2/T</b>	2 - number of rails in profile T - possibility of panel blind

# Type of japanese panel: 3-rails profile

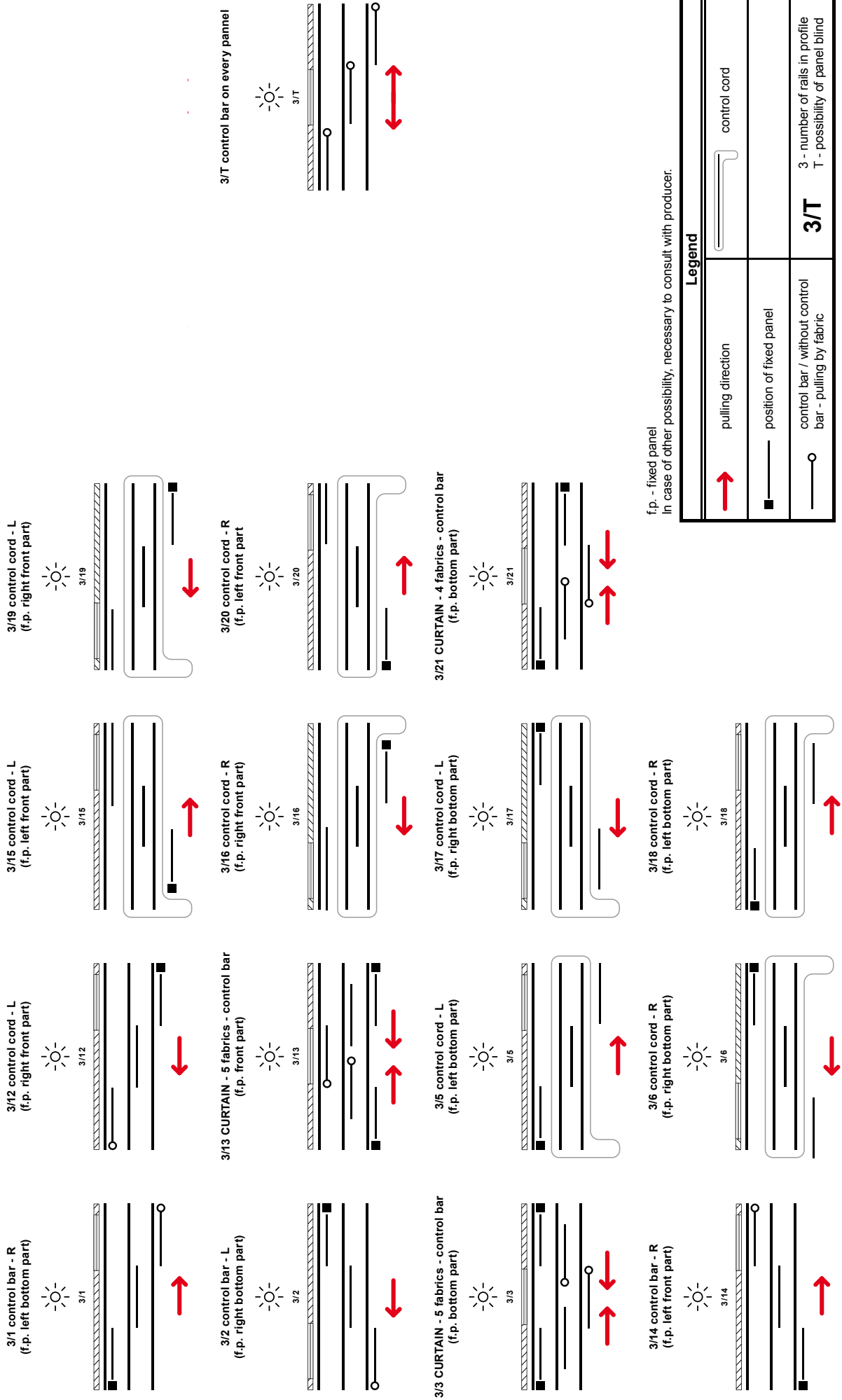

f.p. - fixed panel  
In case of other possibility, necessary to consult with producer.

Legend	
	pulling direction
	position of fixed panel
	control bar / without control bar - pulling by fabric
<b>3/T</b>	3 - number of rails in profile T - possibility of panel blind

# Type of japanese panel: 4-rails profile

4/1 control bar - R  
(f.p. left bottom part)

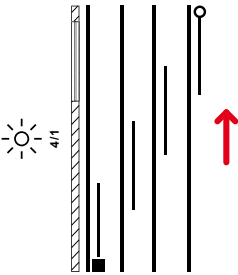

4/2 control bar - L  
(f.p. right front part)

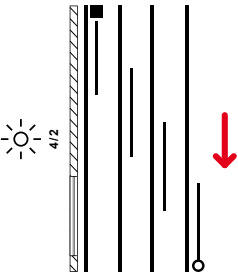

4/3 CURTAIN - 7 fabrics - control bar  
(f.p. bottom part)

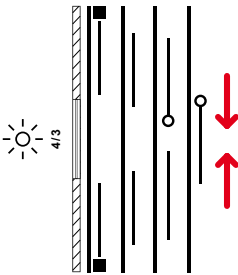

4/14 control bar - R  
(f.p. left front part)

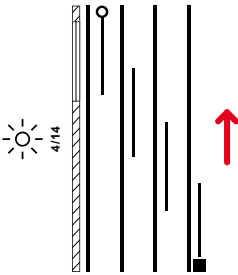

4/12 control bar - L  
(f.p. right front part)

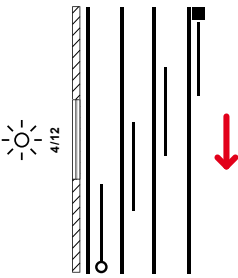

4/13 CURTAIN - 7 fabrics - control bar  
(f.p. front part)

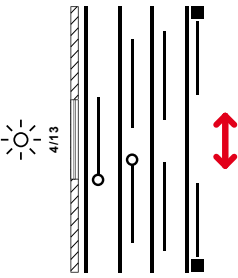

4/5 control cord - L  
(f.p. left bottom part)

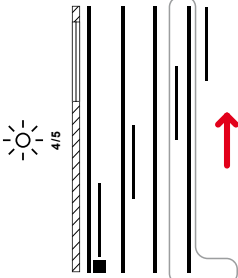

4/6 control bar - R  
(f.p. right bottom part)

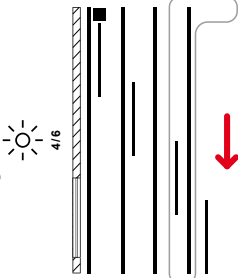

4/15 control cord - L  
(f.p. - left front part)

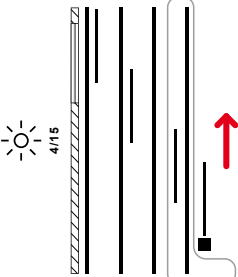

4/16 control cord - R  
(f.p. right front part)

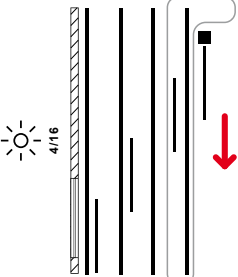

4/17 control cord - L  
(f.p. right bottom part)

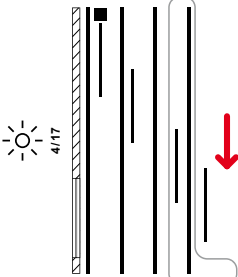

4/18 control cord - R  
(f.p. right bottom part)

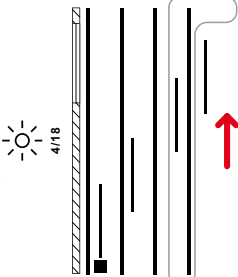

4/19 control cord - L  
(f.p. right front part)

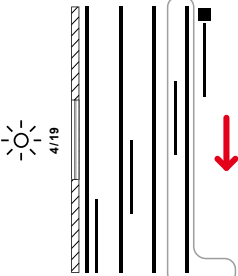

4/20 control cord - R  
(f.p. left front part)

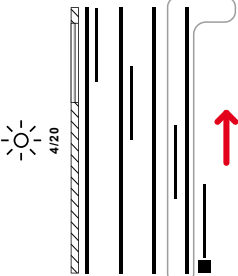

4/21 CURTAIN - 6 fabrics - control bar  
(f.p. bottom part)

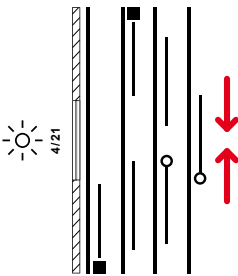

4/7 CURTAIN - 6 fabrics - control cord - L  
(f.p. bottom part)

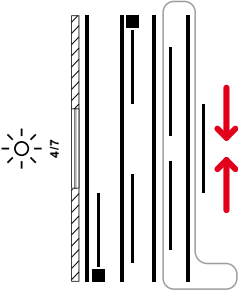

4/8 CURTAIN - 6 fabrics - control cord - R  
(f.p. bottom part)

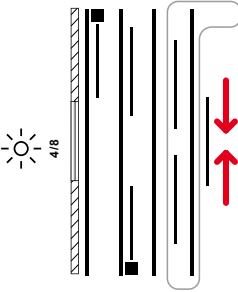

4/T control bar on each panel

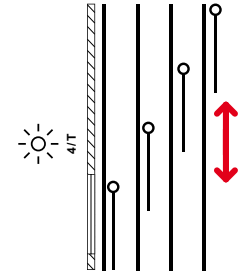

f.p. - fixed panel  
In case of other possibility, necessary to consult with producer.

Legend	
	pulling direction
	position of fixed panel
	control bar / without control bar - pulling by fabric
<b>4/T</b>	4 - numb of rails in profile T - possibility of panel blind

# Type of japanese panel: 5-rails profile

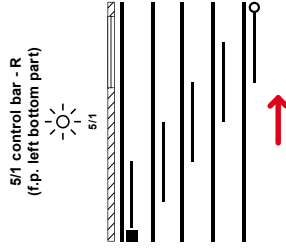
5/1 control bar - R (f.p. left bottom part) 

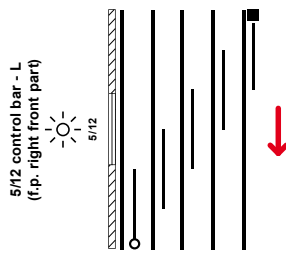
5/2 control bar - L (f.p. right bottom part) 

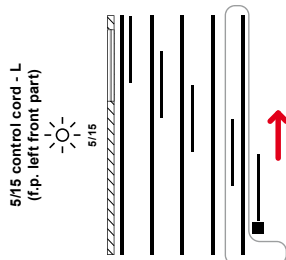
5/3 CURTAIN - 9 fabrics - control bar (f.p. front part) 

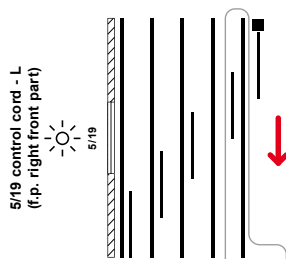
5/4 control bar - R (f.p. left bottom part) 

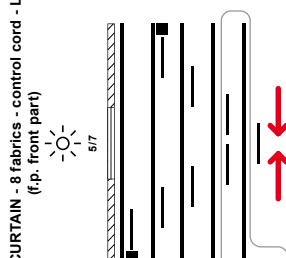
5/5 control bar - L (f.p. left bottom part) 

5/6 control bar - R (f.p. right bottom part) 

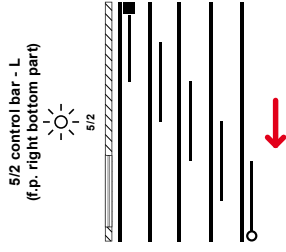
5/7 CURTAIN - 8 fabrics - control cord - L (f.p. front part) 

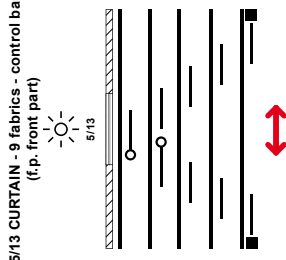
5/8 CURTAIN - 8 fabrics - control cord - R (f.p. bottom part) 

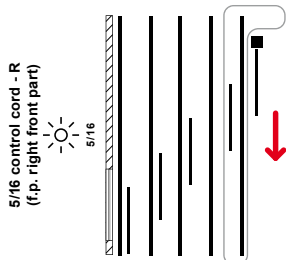
5/9 control cord - L (f.p. left front part) 

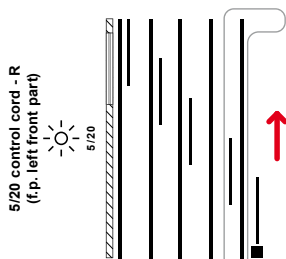
5/10 control cord - R (f.p. left front part) 

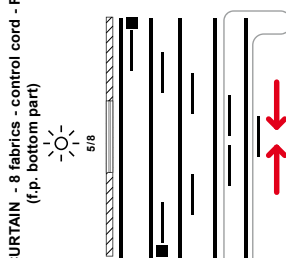
5/11 CURTAIN - 8 fabrics - control bar (f.p. bottom part) 

5/12 control bar - L (f.p. left front part) 

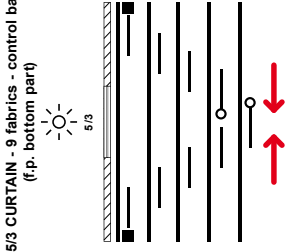
5/13 CURTAIN - 8 fabrics - control cord - R (f.p. bottom part) 

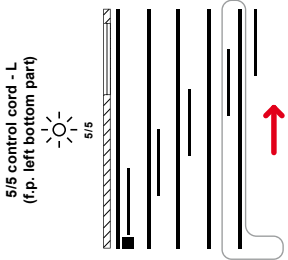
5/14 control bar - R (f.p. left front part) 

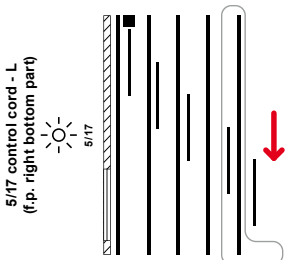
5/15 control cord - L (f.p. left front part) 

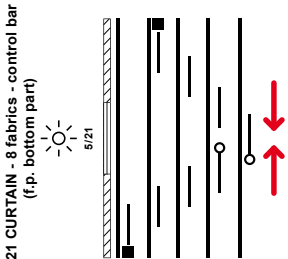
5/16 control cord - R (f.p. right front part) 

5/17 control cord - L (f.p. right bottom part) 

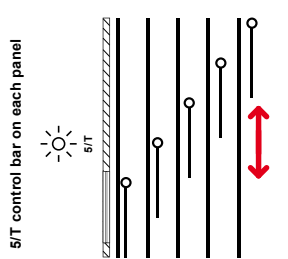
5/18 control cord - R (f.p. left bottom part) 

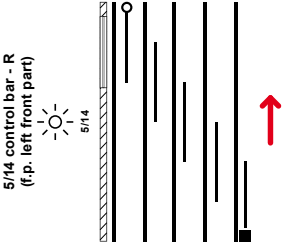
5/19 control cord - L (f.p. left front part) 

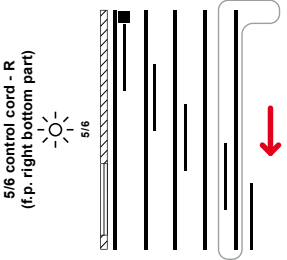
5/20 control cord - R (f.p. left front part) 

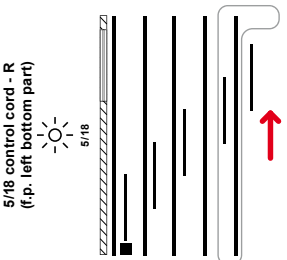
5/21 CURTAIN - 8 fabrics - control bar (f.p. bottom part) 

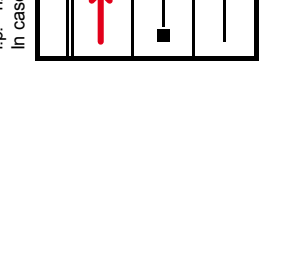
5/22 control bar - L (f.p. left front part) 

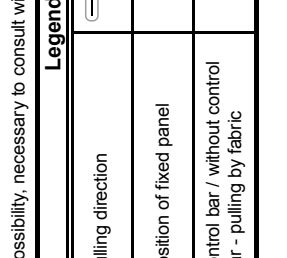

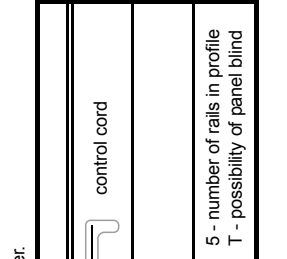
5/23 control bar - R (f.p. right front part) 

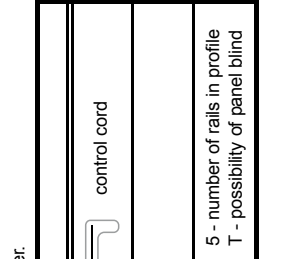
5/24 control bar - L (f.p. left front part) 

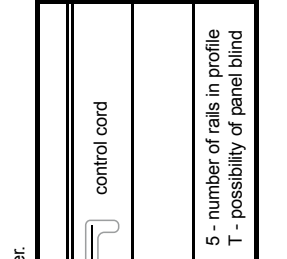
5/25 control bar - R (f.p. right front part) 

5/T control bar on each panel 

f.p. - fixed panel  
In case of other possibility, necessary to consult with producer.

Legend	
	pulling direction
	position of fixed panel
	control bar / without control bar - pulling by fabric
<b>5/T</b>	5 - number of rails in profile T - possibility of panel blind

**Safety features according** to the standards EN 13120+A1; EN 16 433; EN 16 434



Connection



Pulley



Winch



Two wheels

INTERIOR SHADING	Safe type of operation						Dangerous operation			Suitability of ISOTRA protective systems			
	Manually	Wheel	Handle	Switch	Remote control	Control bar	Cord	Cord/Rod	Ball-chain	Coupler	Pulley	Reel	Two wheels
<b>HORIZONTAL BLINDS</b>													
ISOTRA SYSTEM HIT													
ISOTRA SYSTEM HIT II													
ISOTRA SYSTEM CLASSIC													
ISOTRA ENERGY													
ISOLITE													
ISOLITE PLUS													
NEOISOLITE													
SYSTEM 25S, 25SM													
SYSTEM 25R													
SYSTEM 25L (large)													
SYSTEM 25K													
SYSTEM 25SW													
SYSTEM 25M													
CETTA 35, 50 - ECONOMY													
CETTA 35													
CETTA 50 (usage in interior)													
V-LITE INTERIOR ROOF BLIND													
ATYPICAL CHAIN BLINDS													
CHAIN BLINDS WITH BRAKE													
CHAIN BLINDS (space > 2,5 m²)													
<b>VERTICAL BLINDS</b>													
<b>JAPANESE PANEL BLINDS</b>													
<b>FABRIC ROLLER BLINDS</b>													
VERRA													
VERA METAL													
ROLLITE													
LUNA													
SUNLITE													
NEMO													
<b>SHADING ROLLER BLIND</b>													
<b>R-LITE ROOF ROLLER BLIND</b>													



**ISOTRA a.s.**

Bílavecká 2411/1, 746 01 Opava  
Czech Republic

Tel.: +420 **553 685 111**  
E-mail: [isotra@isotra.com](mailto:isotra@isotra.com)

[www.isotra.com](http://www.isotra.com)

Released: 05/2026

**ISOTRA Partner**



*... protecting your privacy.*